

Fully Closed



Airflow Position



Fully Open

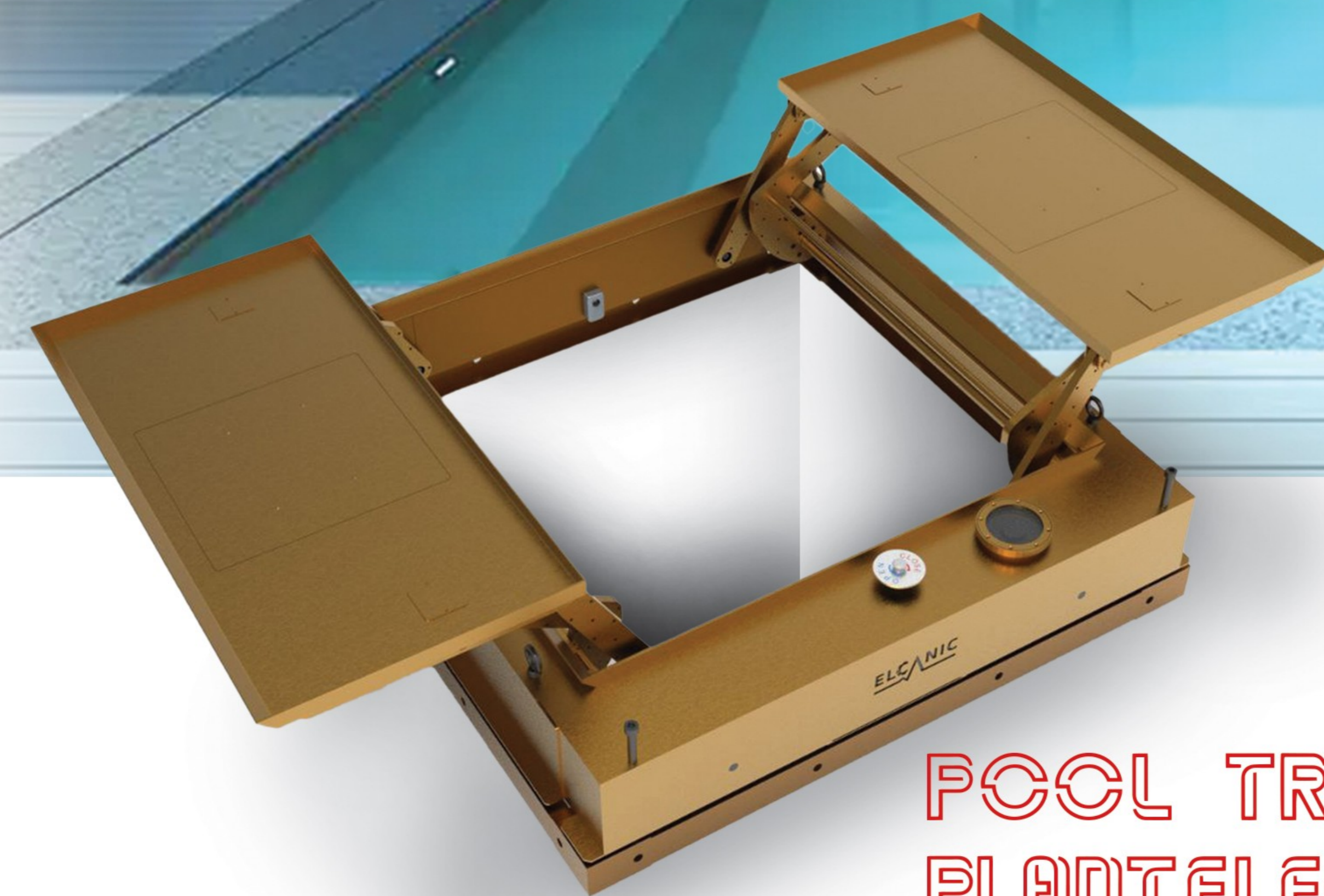

**POOL TREATMENT
PLANT ELECTRIC DOOR**
(24V) Dimensions 110x110 cm



OPTIONAL ITEMS:

- smoke, humidity, temperature and O2 sensors
- Online backup battery during power outages

SPECIAL FEATURES :

- Optical sensor: stops the door movement if it detects an obstacle while opening or closing
- Lifting capacity when opening the door: 150 kg
- Excellent sealing when the door is closed
- Fan activation during air circulation mode
- Interior light activation during door opening mode
- Manual lever for opening the door
- Connectable to the Building Management System (BMS)
- Includes 2 remote controls with hopping code
- Operates on 24 V
- Automatic air conditioning system (opens 4 times within 24 hours, each cycle lasting 15 minutes)
- Camouflage Coating
Blends the door with its surroundings to create a discreet and unified appearance.

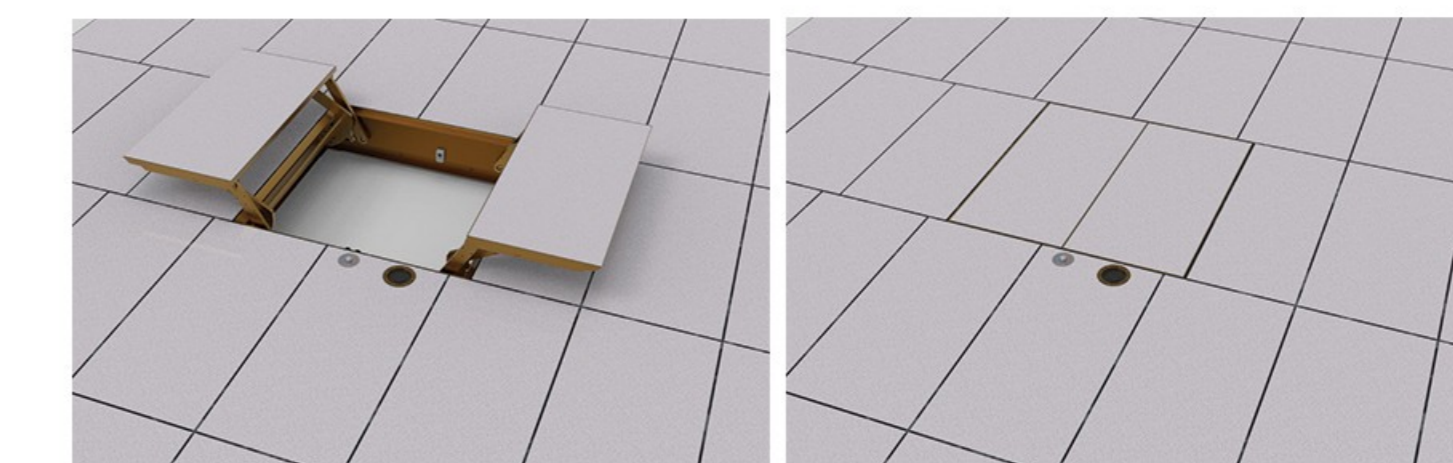

LINEAR VIEW

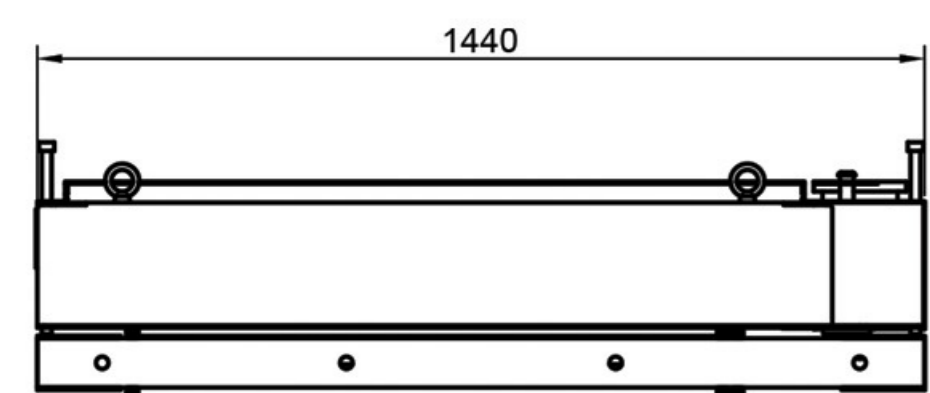

fully Closed

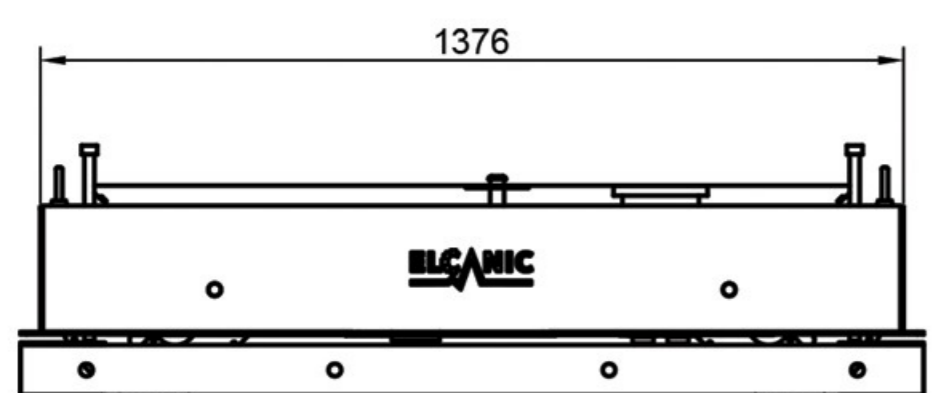

Airflow Position

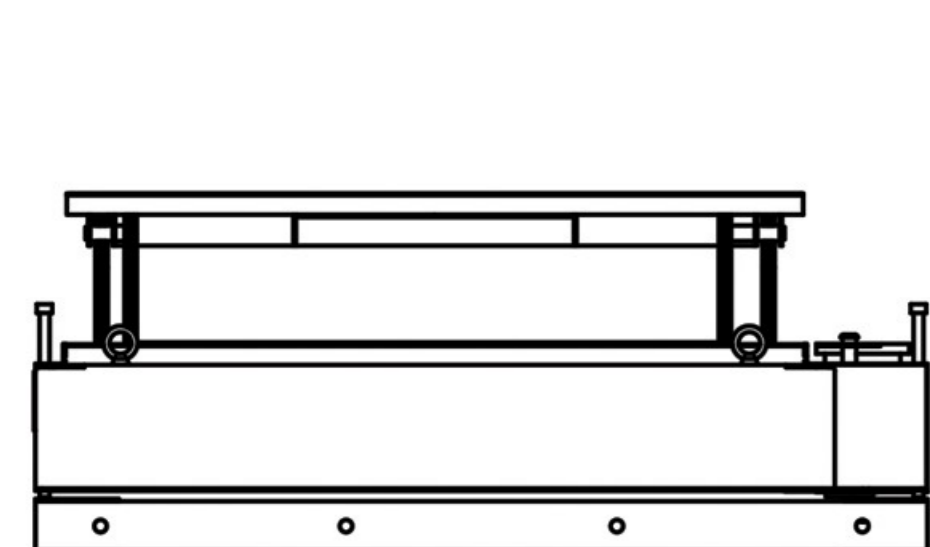
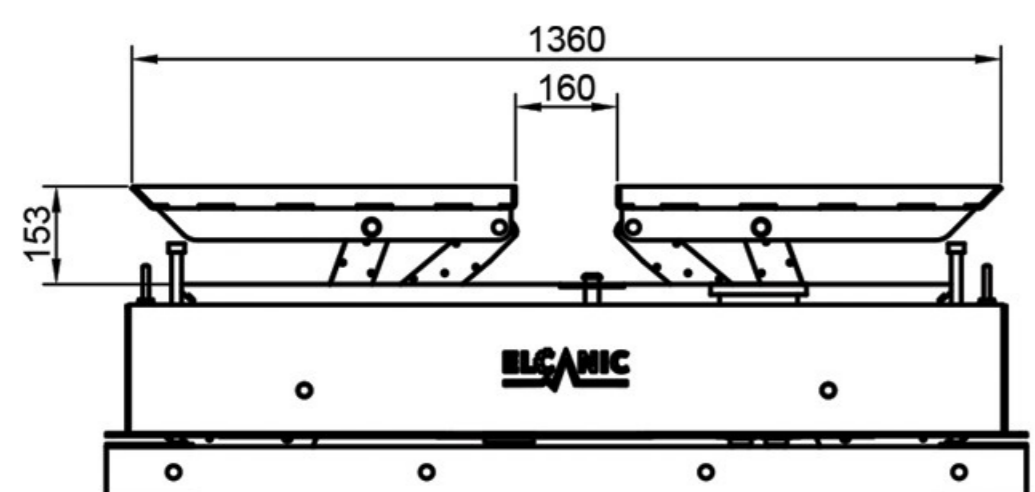
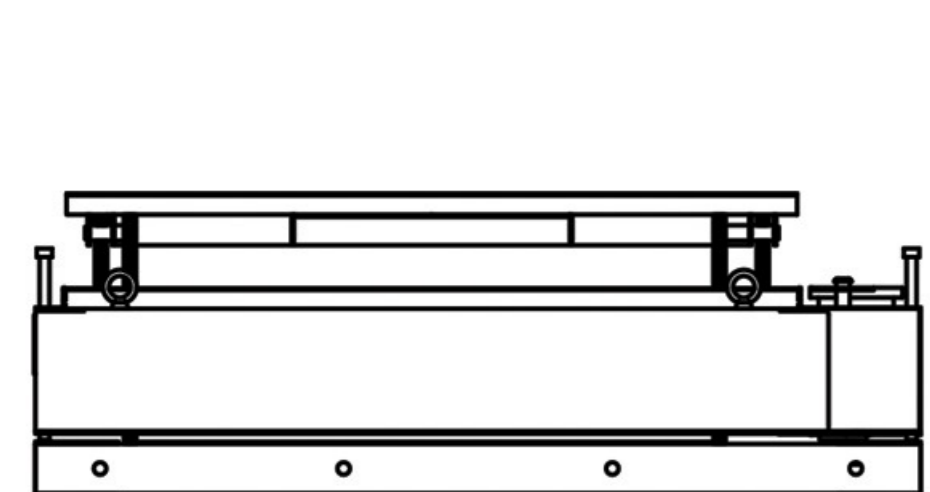

fully Open

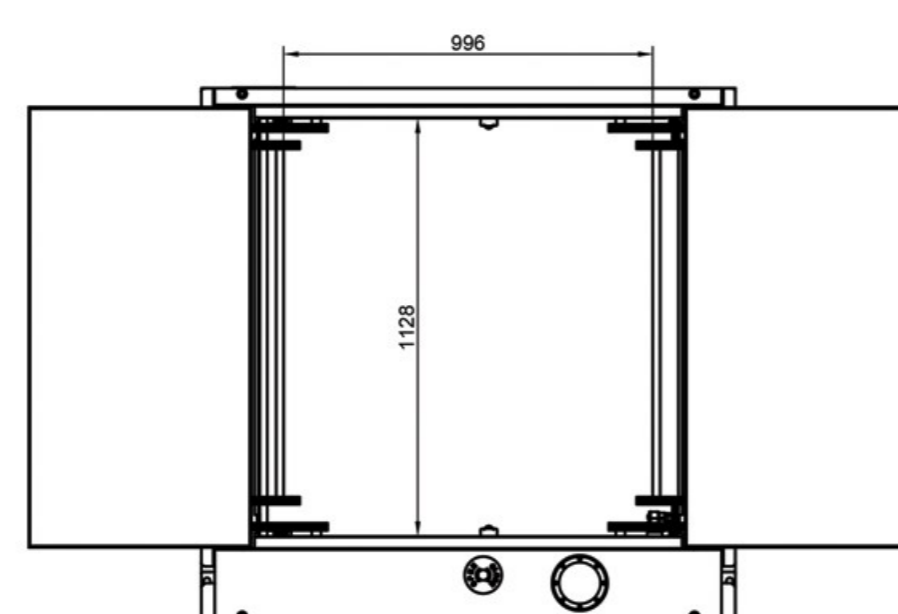
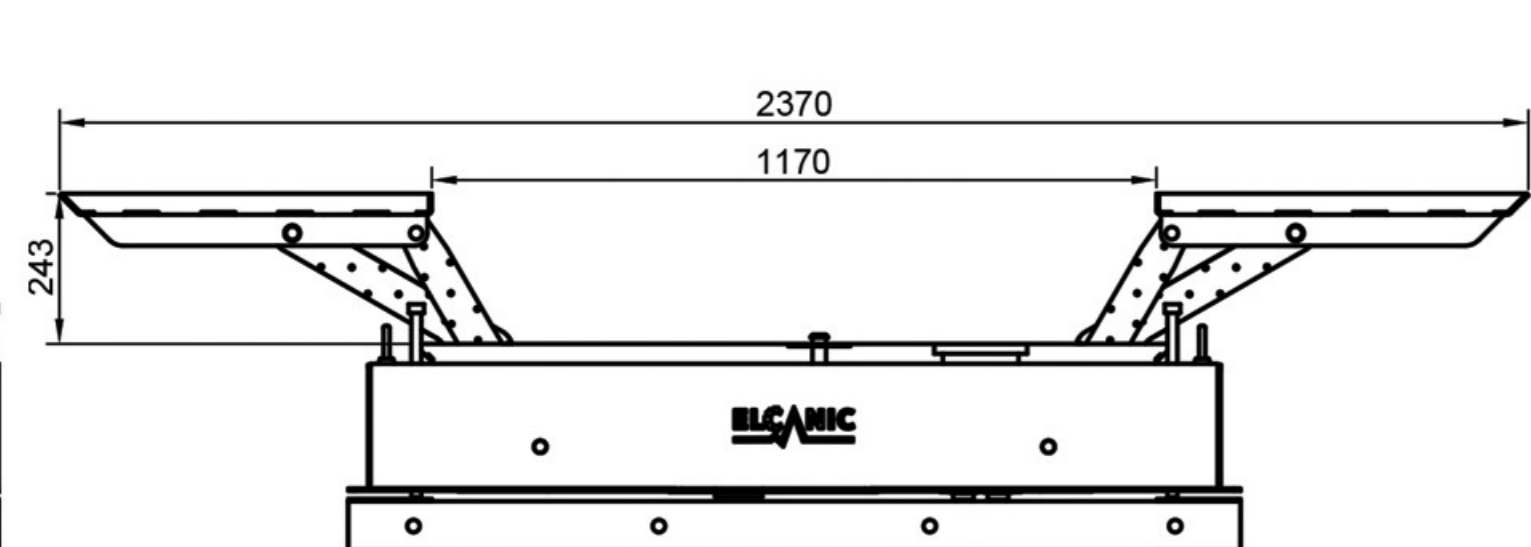

4th floor, Mehrdad Building, between 25 and 27
Aftab alley, Haraz St., Amol, Mazandaran, Iran

+98 912 35 00 642 - 902 35 00 642

elcanic.com

DETAILS

